



Siebe Environmental Controls
1354 Clifford Avenue (Zip 61111)
P.O. Box 2940
Loves Park, IL 61132-2940
United States of America

A Siebe Group Company

AV-496

**Valve Linkage for MK-88XX
and MK-89XX Actuators
General Instructions**

Application

The AV-496 valve linkage kit is used to field assemble MK-88XX and MK-89XX series actuators to 2½ inch through 6 inch VB-9XXX series valve bodies, except VB-9323.

Features

- Die cast aluminum mounting bracket.
- Valve position indication provided as standard.

Applicable Literature

- Siebe Environmental Controls Cross-Reference Guide, F-23638
- Siebe Environmental Controls Reference Manual, F-21683
- Siebe Environmental Controls Application Manual, F-21335
- Siebe Environmental Controls Catalog, F-25683
- AK-42309-500 Positive Positioner Pneumatic Relay General Instructions, F-22909
- EN-205 Water System Guidelines, F-26080

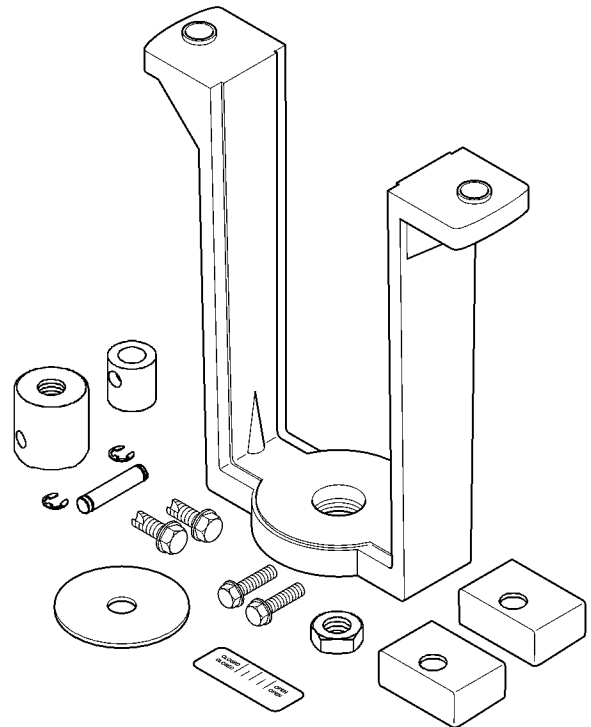

SPECIFICATIONS

Table-1 AV-496 Valve Linkage Component Selection.

Valve Body ^a	Actuator	Lock Nut	Spacers	Stem Adapters	Stem Link Shaft	E-rings	Mounting Bracket Bolts	Indicating Plate	Scale Length
2-1/2 to 4" VB-9XXX	MK-88XX	1/2"	—	2 for 1/2" stem	1	2	2 1-1/4" long	1 with 1/2" hole	1" (25.4mm)
5 & 6" VB-9XXX	MK-89XX	1/2"	2	2 for 1/2" stem	1	2	2 2-1/4" long	1 with 1/2" hole	2" (50.8mm)

^a Except VB-9323 series valves.

INSTALLATION

Inspection

Inspect the package for damage. If damaged, notify the appropriate carrier immediately. If undamaged, open the package and inspect the device for obvious damage. Return any damaged products.

Requirements

- Tools:
 - Open end wrench, 3/4 inch
 - Slotted screw driver
 - Scale for measuring the gap between valve stem and actuator shaft
- Training: Installer must be a qualified, experienced technician

Caution:

- Avoid locations where excessive moisture, corrosive fumes, or vibration is present.
 - Install all two-way valves so that they close against the flow. An arrow on the valve body or a tag indicates the proper flow direction.
 - Always install three-way mixing valves with two inlets and one outlet.
 - Do not install the actuator below the center line of the valve. For steam applications mount the actuator above the valve body at 45° from vertical.
-

Linkage Kit Installation



Two-way Normally Open VB-9213 2½” through 6” Valve Bodies

Warning: 2½” through 6” valve bodies date coded before 8603 must have valve packing nut removed and replaced [replace packing nut — tighten four (4) turns] along with the bracket nut. Before removing packing nut, isolate the valve body using shutoff valves or depressurize system to zero gauge and drain piping. System pressure could cause packing parts to blow out with potential of bodily injury and/or water damage.

1. Push the valve stem completely down.
2. Remove bracket nut from valve body. Refer to Figure-1.
3. Place mounting bracket onto valve body and secure it in place with the bracket nut.
4. Thread the stem lock nut all the way down the valve stem.
5. Place the indicator plate on the valve stem.
6. Install an E-ring on one end of stem link shaft (pin). Insert the pin through the holes of the valve stem adapter.
7. Thread the valve stem adapter onto the valve stem until the stem touches the pin. Back the adapter off ½ turn (counterclockwise) and remove the pin.
8. Secure the valve stem adapter, the AK-42309-500 spring arm (if required), and the indicator plate into place with the stem lock nut. Refer to Figure-1.

Note: For actuator/valve assemblies that require a positive positioner, refer to **AK-42309-500, Positive Positioner Pneumatic Relay General Instructions, F-22909**, for details.

9. Select the actuator (MK-88XX or MK-89XX series). For actuators details refer to **MK-8800 Series, MK-8900 Series, Pneumatic Valve Actuators General Instructions, F-21662**.
10. Thread actuator shaft adapter onto the actuator shaft as far as it will turn. Refer to Table-1 for required AV-496 components.
11. Using the appropriate bolts attach the selected actuator to the mounting bracket. Refer to Table-1. If MK-89XX series actuator is selected, install the spacers before attaching the actuator to the bracket. Refer to Figure-1.
12. Turn actuator shaft adapter (counterclockwise) until the distance between the surface of the two adapters is 1.100” (for 5” and 6” valves with 2” stroke) or 0.100” (for 2-1/2” to 4” valves with 1” stroke). Use a scale or caliper to measure the distance.
13. Raise the valve stem to slide the valve stem adapter into the actuator shaft adapter.
14. Align the holes on both sides of the adapter assembly.
15. Insert the stem link shaft (pin) through the holes and place the second E-ring on the other end to secure the assembly.
16. Align the top indication marker of the OPEN/CLOSE decal with the indicator plate. Affix the OPEN/CLOSE decal to the mounting bracket. Refer to Figure-1.
17. Linkage assembly is complete. Refer to Figure-2 and Figure-3.

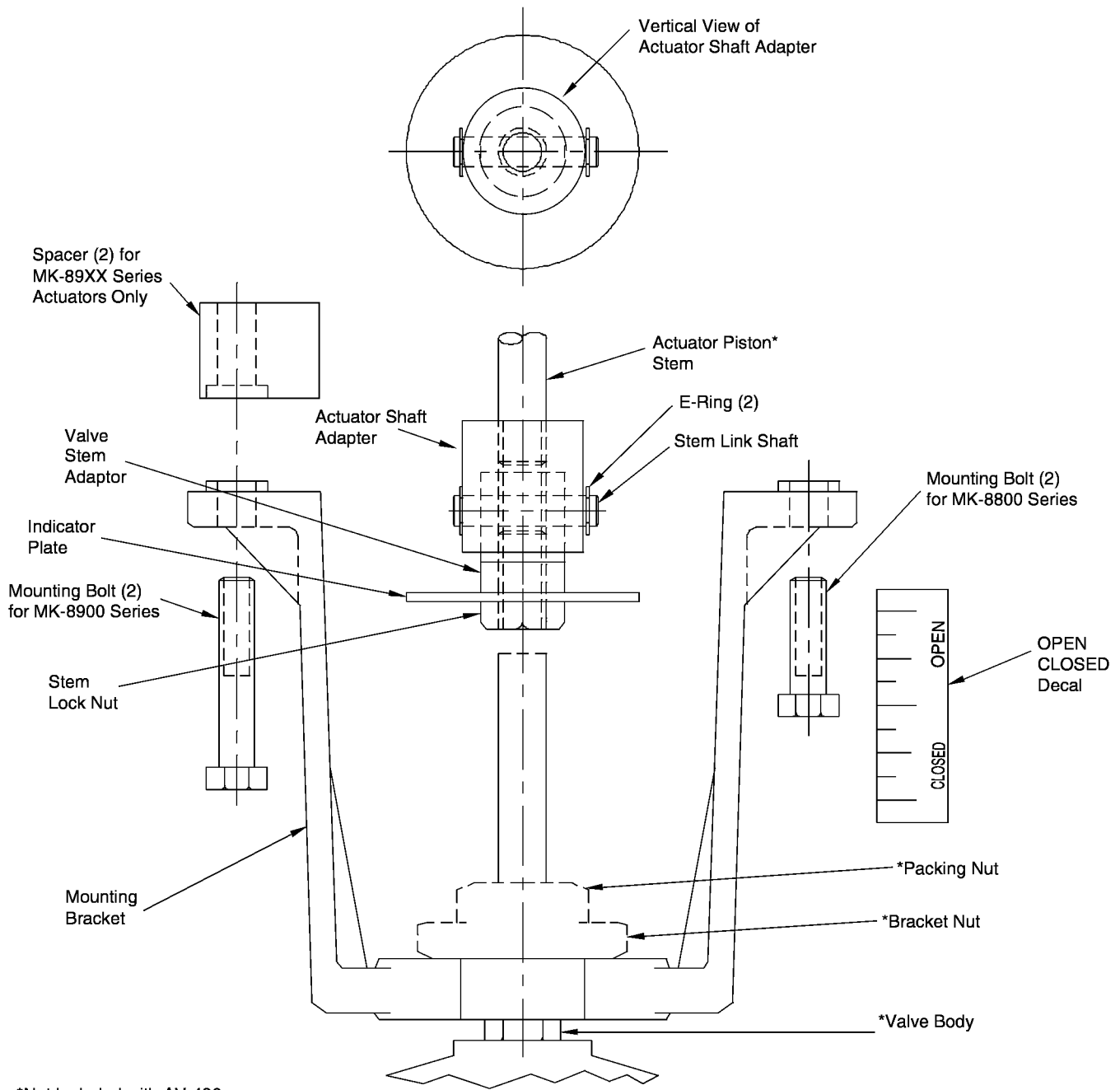

Figure-1 AV-496 Valve Linkage Kit Components.

Linkage Kit Installation (Continued)



Two-way Normally Closed VB-9223 2½” through 6” and Three-way Mixing VB-9313 2½” through 6” Valves Bodies

Warning: 2½” through 6” valve bodies date coded before 8603 must have valve packing nut removed and replaced [replace packing nut — tighten four (4) turns] along with the bracket nut. Before removing packing nut, isolate the valve body using shutoff valves or depressurize system to zero gauge and drain piping. System pressure could cause packing parts to blow out with potential of bodily injury and/or water damage.

1. Push the stem completely down.
2. Remove the bracket nut from valve body. Refer to Figure-1.
3. Place the mounting bracket onto the valve body and secure it in place with the bracket nut.
4. Thread the stem lock nut all the way down the valve stem.
5. Place the indicator plate on the valve stem.
6. Install an E-ring on one end of the stem link shaft (pin). Insert the pin through the hole on the valve stem adapter.
7. Thread the valve stem adapter onto the valve stem until the stem touches the pin. Back the adapter off ½ turn (counterclockwise) and remove the pin.
8. Secure the valve stem adapter, the AK-42309-500 spring arm (if required), and the indicator plate into place with the stem lock nut. Refer to Figure-1.

Note: For actuator/valve assemblies that require a positive positioner, refer to **AK-42309-500, Positive Positioner Pneumatic Relay General Instructions, F-22909**, for details.

9. Select the actuator (MK-88XX or MK-89XX series). For actuators details refer to **MK-8800 Series, MK-8900 Series, Pneumatic Valve Actuators General Instructions, F-21662**.
10. Thread the actuator shaft adapter onto the actuator stem as far as it will turn. Refer to Table-1 for required AV-496 components.
11. Using the appropriate bolts attach the selected actuator to the mounting bracket. Refer to Table-1. If MK-89XX series actuator is selected install the spacers before attaching the actuator to the bracket. Refer to Figure-1.
12. Raise the valve stem completely up, so that the disc rest against the top seat.
13. Turn the actuator shaft adapter counterclockwise until the holes on the adapters are aligned.
14. Screw the actuator shaft adapter 1½ turns further clockwise onto the actuator shaft.
15. Apply air pressure to actuator until the holes on the adapters are aligned.
16. Insert the stem link shaft (pin) through the holes and place the second E-ring on the other end to secure the assembly.
17. Release pressure to actuator and allow valve assembly to spring return to the closed position.
18. Align the top indication marker of the OPEN/CLOSE decal with the indicator plate. Affix the OPEN/CLOSE decal to the mounting bracket. Refer to Figure-1.
19. Linkage assembly is complete. Refer to Figure-2 and Figure-3.

MAINTENANCE

The actuator linkage requires no maintenance. Regular maintenance of the total system is recommended to assure sustained optimum performance. Hard water leaves abrasive deposits and reduces component life. To maximize valve life, consult **EN-205 Water System Guidelines, F-26080**.

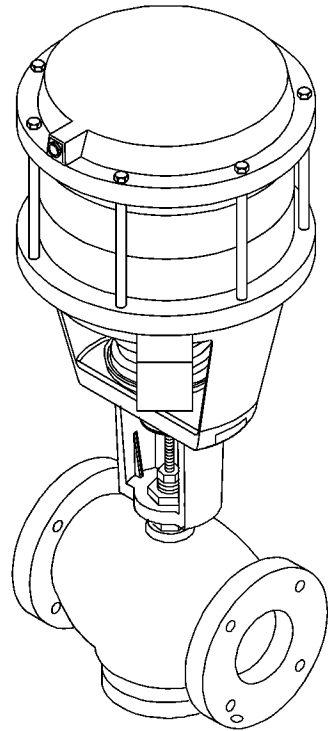

Figure-2 MK-8800 Series Actuator Valve Assembly.

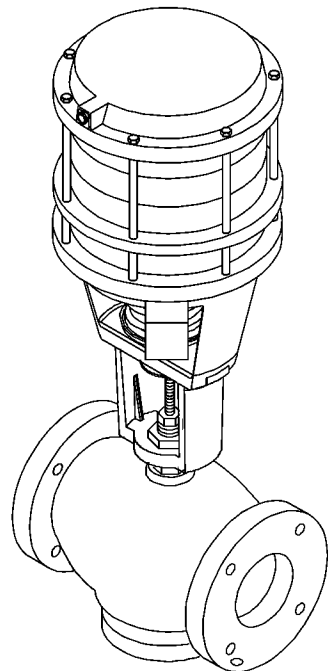

Figure-3 MK-8900 Series Actuator Valve Assembly.

